



CSE 833 IX



3 induction hobs

- Glass-ceramic cooktop.
- 2 round hobs 3 kW, Ø 195 mm.
- 1 round hob 3,6 kW, Ø 270 mm.
- Total power : 9,6 kW.
- Power supply: 2 x 230 V or 400V+N+E.
- 9 power settings.
- Touch control panel on the front.
- Digital power display (1-9).

CSE 833 IX

L 800 - D 650 - H 300

3 induction hobs

CSE 833 IX

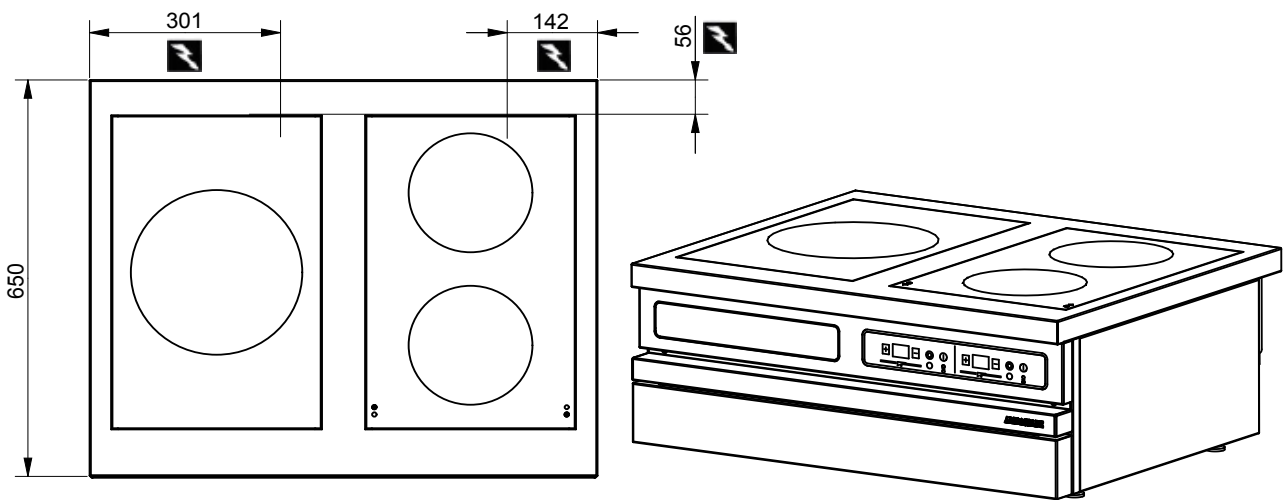
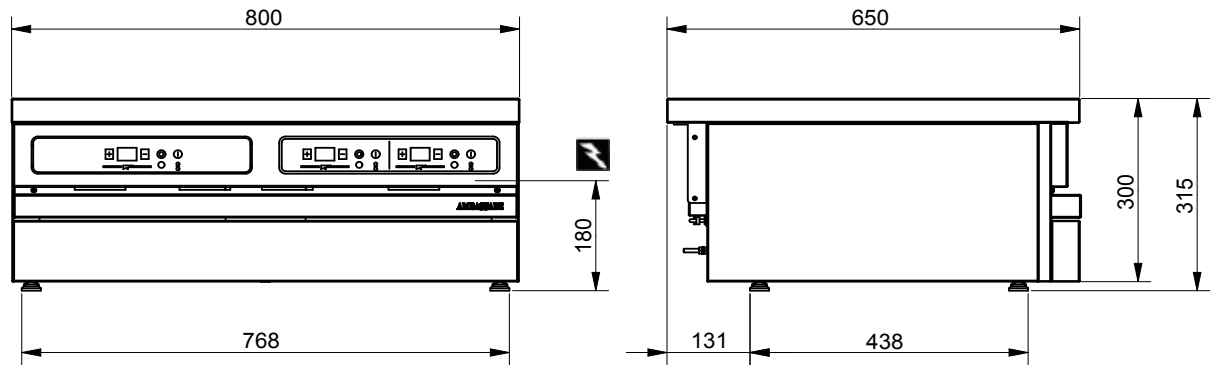

The Chef's Choice.