

# Electric fryer



## CME 628 FRI

2 x 8 L electric fryer - 2 x 8 kW.

CE

- Fixed stainless steel embossed tanks with cool zone.
- Drain valve.
- Thermostat 60/180°.
- Safety thermostat.
- Removable heating element unit.
- Timers: 15 mn.
- Power supply: Tri 400 V.
- Supplied with 2 large baskets.
- Option: single-phase 230 V (with supplement).

**CME 628 FRI**

L 600 – D 650 – H 900

**AMBASSADE**  
DE BOURGOGNE

*The Chef's Choice.*

# 2 x 8 L electric fryer - 2 x 8 kW

# CME 628 FRI

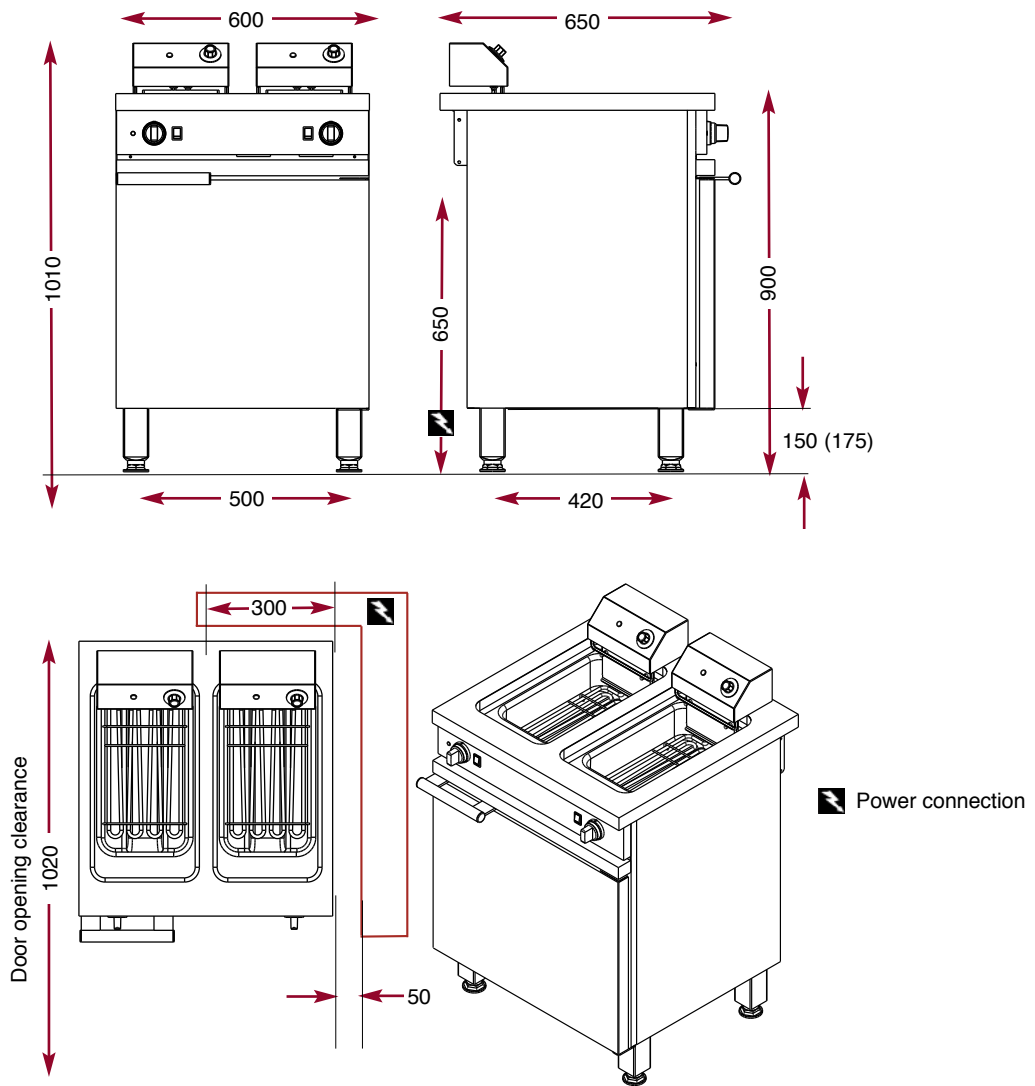

Hot zone complying with standards.

Large cool zone.

Embossed tank with rounded corners for easy maintenance and impeccable hygiene.

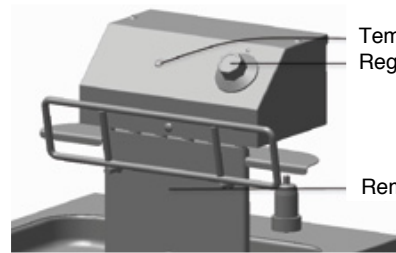
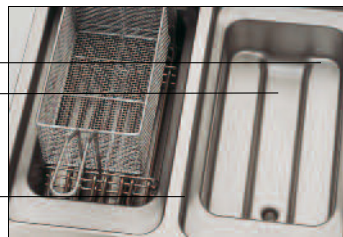

Temperature light indicator  
Regulation thermostat

Removable eating element unit

### Production capacity of electric fryers (\*whitened, then browned continuously)

Appliance	Frozen fries*			Fresh fries*			Basket capacity (in g.)
	Cooking time (in mn)	Hour production (in kg)	Number of portions	Cooking time (in mn)	Hour production (in kg)	Number of portions	
<b>E 628 FRI</b>	5'00"	29,0	170	4'30"	33,0	188	<b>1200</b>

\*The fryers are all equipped with a thermostat set to 180°C.



**The Chef's Choice.**